



Lumin Smart Panel - Outdoor

DOCUMENTATION AND INSTALLATION MANUAL



U.S. Patent No. 10,109,987

U.S. Patent No. 10,467,712

Canadian Patent No. 3,050,702

U.S. and International Patent Applications Pending.

® U.S. Registered Trademark.

Copyright © 2022 Coulomb, Inc. (DBA Lumin). All rights reserved.

TABLE OF CONTENTS

INTRODUCTION.....	1
READ BEFORE USE	3
Warnings	3
SYSTEM DESIGN CONSIDERATIONS	4
INSTALLATION.....	5
Items in the Box.....	5
Required Materials (Not Included).....	6
Required Tools.....	7
Hardware Installation Overview.....	8
Hardware Installation Steps	9
Configuration and Account Setup.....	32
TROUBLESHOOTING AND REPAIRS	36
End User	36
Qualified Installer	36
OPERATIONAL INFORMATION	37
PRODUCT SPECIFICATIONS.....	38
LIMITED WARRANTY FOR LUMIN SMART PANEL.....	39
RADIO FREQUENCY STATEMENT	40



This page intentionally left blank

INTRODUCTION

Welcome! The Lumin Smart Panel (LSP) is a standalone product that extends the capability of an existing circuit breaker panel (or “electrical panel”) by providing measurement and remote control of up to twelve (12) circuits in a home or building. The function of the circuit breaker panel remains the same and is not impacted. The LSP securely and safely transmits real-time consumption information to the cloud via Ethernet connection (preferred) or customer WiFi.

This product is designed to be used as an Energy Management System with overload control. It can perform either of the following functions, or both:

Panel Guard: Limits the current on a busbar or conductor and reduces the need for upsized load centers and other equipment when adding new loads such as electric vehicle charging equipment.

Off-Grid Manager: Limits the demand on an energy storage system (battery) or a generator and sheds loads as the state of charge of a battery decreases, thus increasing the number of loads a battery of a certain size can be connected to and extending battery run time.

Unless otherwise noted, each installation step in this document is required for both **Panel Guard** and **Off-Grid Manager**. Installation steps only required for one function or the other will include specific instructions on how to omit that step when not required for your application. If you are using the product for both applications simultaneously, complete all steps as instructed.

Data and system controls can be accessed via the Lumin Energy app (<https://get.lumin.energy>) or the web-based Lumin dashboard (<https://lumin.energy>). The Lumin Energy app gives customers insights into their energy consumption, as well as providing the user with the ability to monitor and prioritize their energy use remotely.

NOTE: A Lumin Smart Panel will not function as designed until it is fully commissioned. It is the responsibility of the installer to perform both the physical installation and the online setup/commissioning process. Refer to pg. 32 to begin the setup process. All qualified persons



installing this product must complete Lumin Certified Installer Training prior to installation. Only Certified Installers can access and change current limiting settings. Scan below to register for training.



Need help? For installation assistance please contact Lumin by e-mail at support@luminsmart.com or by phone at 1-888-421-0616 (North America).



DANGER: HAZARDOUS VOLTAGES PRESENT DURING INSTALLATION AND SERVICING. PRECAUTIONS AND QUALIFICATIONS REQUIRED. REFER TO THE FOLLOWING PAGE.



PELIGRO: VOLTAJES PELIGROSOS PRESENTS DURANTE LA INSTALACIÓN Y EL MANTENIMIENTO QUE, SI NO SE EVITAN, PODRÍAN PROVOCAR LA MUERTE O LESIONES GRAVES. PRECAUCIONES Y CALIFICACIONES REQUERIDAS. CONSULTE LA PÁGINA SIGUIENTE.



DANGER: TENSIONS DANGEREUSES PRÉSENTES LORS L'INSTALLATION ET L'ENTRETIEN. PRÉCAUTIONS ET QUALIFICATIONS REQUISES. REPORTEZ-VOUS À LA PAGE SUIVANTE.

READ BEFORE USE

The LSP interfaces with existing electrical panels and includes conduit/fittings for installation with surface-mount electrical panels. Verify the label model number is LSP-12-OR before performing an outdoor installation. Please review the product's technical ratings and specifications (pg. 38) to confirm it is suitable for your application prior to installation.

NOTE: The *LSP Circuit Label & CT Table* (provided with the LSP) must be completed for setup and delivered to the home/building owner upon the successful installation of the LSP.



Warnings

LSP installation and servicing involves dangerous voltages that can cause injury or death. In addition to specific instructions accompanied by the  symbol throughout this booklet and product labeling, observe the following safety precautions:

- Installation and servicing must be conducted by qualified persons, according to local and national electrical codes
- Lumin Certified Installer training is required for installation and servicing. The installation cannot be completed without Certified Installer credentials.
- Review entire manual before starting the installation or servicing
- Personal protective equipment should be worn when installing or servicing the product
- Do not install or operate the LSP other than intended or outside the conditions specified on pg. 38
- Do not open, attempt to access, or touch any internal product parts — dangerous voltages would be exposed even if main service feed is disconnected
- Do not use the product if it is damaged or appears to be damaged
- Use only the wires and cables supplied with the product
- Power relays are evaluated for 100,000 cycles at a 1.5 HP inductive load (e.g., motors) — larger loads of this type may result in premature relay failure
- The product warranty does not cover damage due to lightning. Lumin recommends the installation of a whole-home Surge Protective Device (SPD) such as ABB's THQLSURGEP7 or THOMESURGE to prevent product damage due to lightning strike
- This manual covers outdoor surface mounted electrical panel installations only. Connecting the LSP conduit to an outdoor recessed electrical panel is the sole responsibility of the installer and shall be done in accordance with all local codes and regulations.



SYSTEM DESIGN CONSIDERATIONS

- The LSP should be mounted so that the connected electrical panel is within reach of the LSP's flexible conduit nipple. The nipple extends 13" beyond the left face or 9" beyond the right face of the LSP enclosure. Ensure that the electrical panel has adequate wiring space for LSP conductors and connections. Suitable junction boxes and conduit may be used to route and/or extend LSP conductors if needed. For voltage drop calculations, assume LSP conductors add 15 one-way-feet to the circuit.
- An LSP requires an always-on Internet connection, either via **Ethernet (preferred if available)** or 2.4 GHz WiFi. Make sure your router is configured with 2.4 GHz enabled. The LSP is only able to connect to 2.4 GHz WiFi networks. **The LSP requires the liquidtight integrity to be maintained at the 3/4" knockout for communication (Ethernet) wiring. Failure to maintain the liquidtight integrity will void the warranty.**
- **Do not control the circuit(s) that power the internet modem and router.** Control of the LSP will not be possible if this equipment is switched off in an off-grid or overload situation.
- The Panel Guard overload control functionality will be most effective when used to shed heavy (greater than 15 A) two-pole loads, especially thermostatic loads like water heating and HVAC as well as battery charging loads such as electric vehicle charging equipment. **More information about circuit selection is provided in the required Lumin Certified Installer Training.**
- The LSP **does not** replace the need for standard circuit breakers. LSP **does not** provide overcurrent protection, ground fault protection, arc fault detection, or other safety functions of circuit breakers.
- The LSP uses current transformers (CTs) to measure overall power flows. Correct placement of these CTs is crucial. See Page 24.
- Selecting the correct maximum current setting and controlled loads is very important. This procedure is detailed in the Certified Installer training. The training material can be reviewed at any time after completing the training.



luminsmart.learnworlds.com

Need help? For system design and installation assistance please contact Lumin by e-mail at support@luminsmart.com or by phone at 1-888-421-0616 (North America).

INSTALLATION

Items in the Box

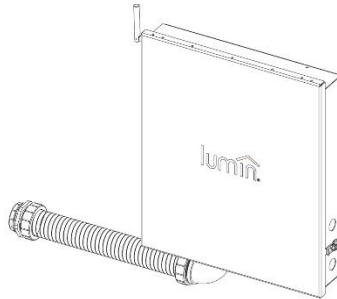

1 Outdoor LSP with Conduit, Conduit Bushings & Wire Whips Attached



Upper Outdoor Wall Mounting Brackets



Lower Outdoor Wall Mounting Brackets

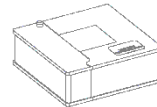
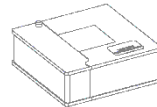

1 Pair of 200A Current Transformers
(Contact Lumin for a second pair when backfed solar PV is present.)

NOTE: Additional items include an antenna, installation hardware, *Lumin Identifier Sticker Sheet*, *Current Setting* sticker, and an *LSP Circuit Label & CT Table*.

Required Materials (Not Included)



Wire splice connectors



Pen or marker

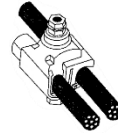

Supply-side/line-side tap
(Optional)



Cable ties (Optional)



3/4" Liquidtight conduit and fittings (for optional ethernet cable)

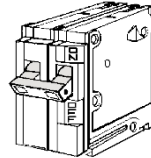

Dual-pole breaker: 15 to 20 amps
(Optional)

NOTE: Additional supplies may be required depending on the existing electrical panel installation. A dual-pole breaker of 15 to 20 amps may be required to power the LSP. Appropriately rated breakers may be double-tapped depending on local electrical codes. See pg. 18 for more details. Liquidtight conduit (3/4" trade size) may be required for communication wiring (see pg. 32). The conduit provided is 2" (trade size) LFNC- B. Additional **liquidtight** conduit and fittings may be required depending on installation conditions. The installer may orient the provided 90° conduit elbow to the left or right side, or replace it with a different 2" (trade size) LFNC fitting.

For outdoor installations: The installation orientation of the LSP must be plumb and level with the conduit fitting at the bottom of the enclosure. All conduit and fittings between the LSP and the electrical panel/s must be **liquidtight conduit**. For communication wiring, the LSP requires the liquidtight integrity to be maintained at the 3/4" knockout. **Failure to maintain the liquidtight integrity of the LSP enclosure will void the warranty.**

Required Tools



Drill

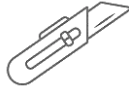

Utility knife

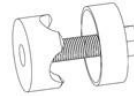

Knockout punch or hole saw for
2" conduit
(2.5" hole size)



Level



Tape measure



Wire stripper

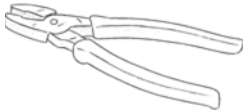

Pliers



Stud-finder (Optional)



Fish tape (Optional)



Phillips screwdriver



Flathead screwdriver



Multimeter

NOTE: A multimeter may be required for determining current transformer placement (see pg. 26).



Hardware Installation Overview

- STEP 1. Turn Off Main Breaker and Remove Electrical Panel Cover
- STEP 2. Knock Out or Punch One Hole for 2" Conduit Fitting
- STEP 3. Determine LSP Mounting Position Relative to Conduit Routing
- STEP 4. Measure and Mark Hole Locations for Mounting
- STEP 5. Secure Mounting Brackets to Wall
- STEP 6. Attach LSP Antenna and Guide LSP Wire Whip into Electrical Panel
- STEP 7. Secure LSP to Wall/Bracket and Electrical Panel
- STEP 8. Connect LSP Equipment Grounding Conductor (EGC) to Ground Bar
- STEP 9. Identify A-Row and B-Row Breakers
- STEP 10. Connect LSP Power Circuit and Label Breaker
- STEP 11. Select Circuit Breaker to Connect to LSP and Disconnect Load Wire
- STEP 12. Connect LSP Wire Labeled "Line 1 Breaker" to Circuit Breaker
- STEP 13. Connect LSP Wire Labeled "Line 1 Load" to Load
- STEP 14. Record Circuit Name and Breaker Row (A/B) With Corresponding LSP Line Number
- STEP 15. Repeat Steps 11-14 Until All LSP Line # Wires Are Connected
- STEP 16. Determine Placement of Current Transformers (CTs)
- STEP 17. Phase Conductors Monitored by Current Transformers
- STEP 18. Test for Breaker Crossover before Current Transformer Placement
- STEP 19. Connect Current Transformers
- STEP 20. Record the Placement of Current Transformers
- STEP 21. Connect Grid Detect Circuit (GDC) (Required for Off-Grid Manager)
- STEP 22. Replace Electrical Panel Cover and Remove LSP Cover
- STEP 23. Energize the Electrical Panel and Turn On the LSP
- STEP 24. LSP Configuration
- STEP 25. Complete Current Limiting Label (for installations with Panel Guard)
- STEP 26. Apply Labels
- STEP 27. Reinstall and Secure LSP Cover

Hardware Installation Steps

STEP 1. Turn Off Main Breaker and Remove Electrical Panel Cover

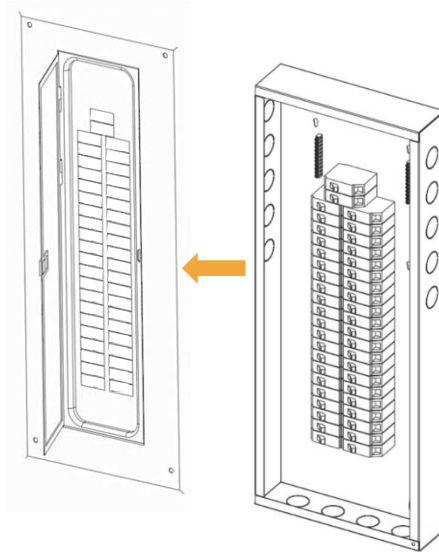

WARNING: HIGH VOLTAGE. ENSURE MAIN BREAKER IS OFF. MAIN SERVICE LINES ARE ALWAYS LIVE.
AVERTISSEMENT: HAUTE TENSION. ASSUREZ-VOUS QUE LE DISJONCTEUR PRINCIPAL EST ÉTEINT. LES CONDUCTEURS DE SERVICE PRINCIPAUX SONT TOUJOURS SOUS TENSION.

Tools: Screwdriver

STEP 2. Knock Out or Punch One Hole for 2" Conduit Fitting

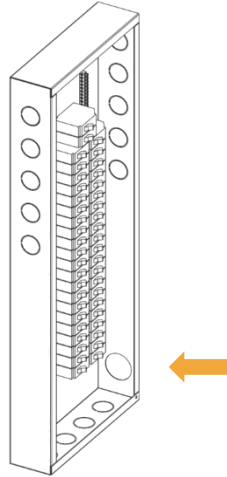

WARNING: HIGH VOLTAGE. ENSURE MAIN BREAKER IS OFF. MAIN SERVICE LINES ARE ALWAYS LIVE.
AVERTISSEMENT: HAUTE TENSION. ASSUREZ-VOUS QUE LE DISJONCTEUR PRINCIPAL EST ÉTEINT. LES CONDUCTEURS DE SERVICE PRINCIPAUX SONT TOUJOURS SOUS TENSION.

Tools: Screwdriver, pliers, drill (optional), and knockout punch (optional)

NOTE: Knockout hole location in electrical panel may vary depending on spacing constraints. Choose a location that avoids existing obstructions and provides adequate clearance for routing of the LSP wire whips. Use of existing pre-stamped 2" knockouts are acceptable provided there is sufficient clearance. Otherwise, a 2" knockout punch (2-1/2" hole) will be required to attach the LSP conduit. The conduit elbow exiting the LSP may be rotated 180° to mount the LSP to the left side of the electrical panel. Additional conduit fittings may be required depending on routing conditions, including installations that utilize the bottom face of the electrical panel. **Ensure the knockout hole location allows vertical mounting of the LSP as shown in the following steps.**

STEP 3. Determine LSP Mounting Position Relative to Conduit Routing

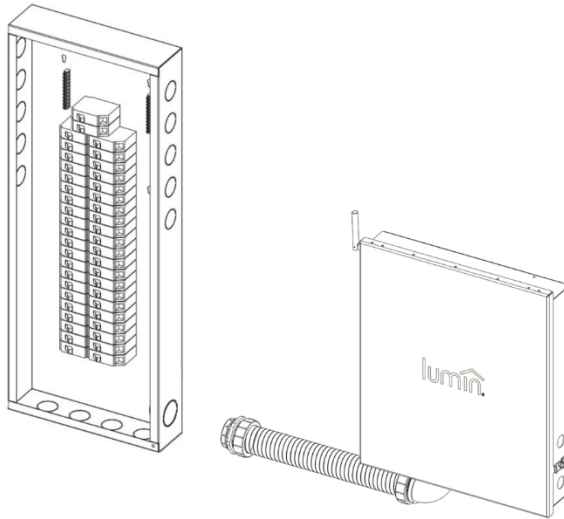

WARNING: HIGH VOLTAGE. ENSURE MAIN BREAKER IS OFF. MAIN SERVICE LINES ARE ALWAYS LIVE.
AVERTISSEMENT: HAUTE TENSION. ASSUREZ-VOUS QUE LE DISJONCTEUR PRINCIPAL EST ÉTEINT. LES CONDUCTEURS DE SERVICE PRINCIPAUX SONT TOUJOURS SOUS TENSION.

NOTE: The LSP must be mounted in the vertical orientation shown (with the conduit exiting the LSP from the bottom). To prepare for mounting, position the LSP in alignment with the knockout hole in the electrical panel. Temporarily feed the wire whips and conduit fitting into the knockout hole.

STEP 4. Measure and Mark Hole Locations for Mounting

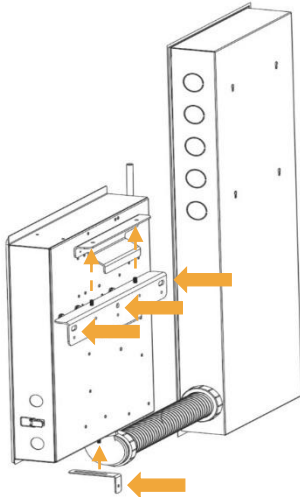

*Location of Mounting Holes and Slots (Large Arrows)
Bracket Attachment Stud Locations (Small Dashed Arrows)*

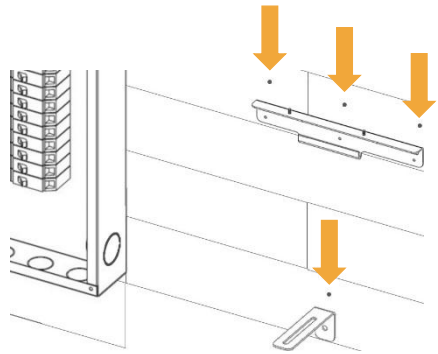

Marking Hole Locations Using Brackets

Tools: Tape measure, marker, stud-finder (optional), and level.

NOTE: The LSP must be mounted in the vertical orientation shown. Verify that the bracket placement provides a level installation without introducing strain on the conduit attachments. Then mark the applicable hole locations using the mounting brackets. Exact hole locations may vary depending on existing conditions. Qty 4 holes are required to sufficiently mount the LSP. The mounting hole for the lower bracket is 19¼" or 19.3" below the center mounting hole of the upper bracket.

STEP 5. Secure Mounting Brackets to Wall

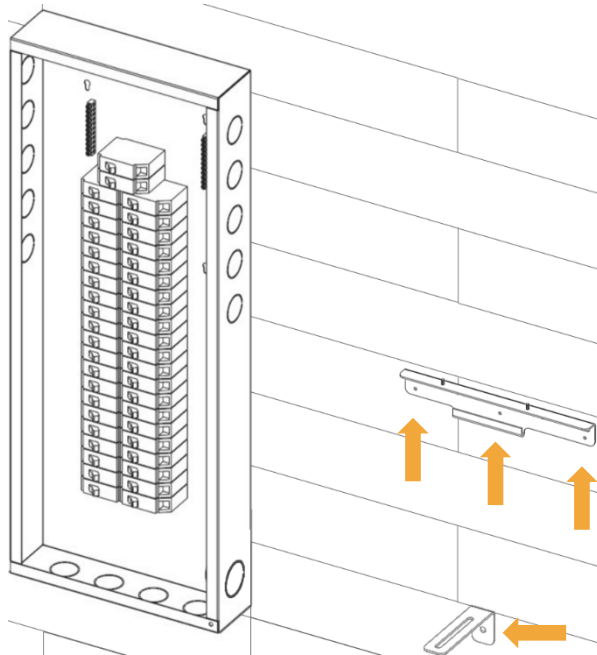

Tools: Drill, stud-finder (optional), screws (x4), and washers (x4)

NOTE: Ensure the outer screws of the upper bracket are securely threaded into studs, sheathing, brick, masonry, or other suitable structural anchors. For masonry applications (including brick) use the appropriate fasteners included in the installation hardware. Exterior cladding such as vinyl or aluminum siding are examples of unsuitable anchors. Secure the LSP to the structure behind exterior cladding systems.

STEP 6. Attach LSP Antenna and Guide LSP Wire Whip into Electrical Panel

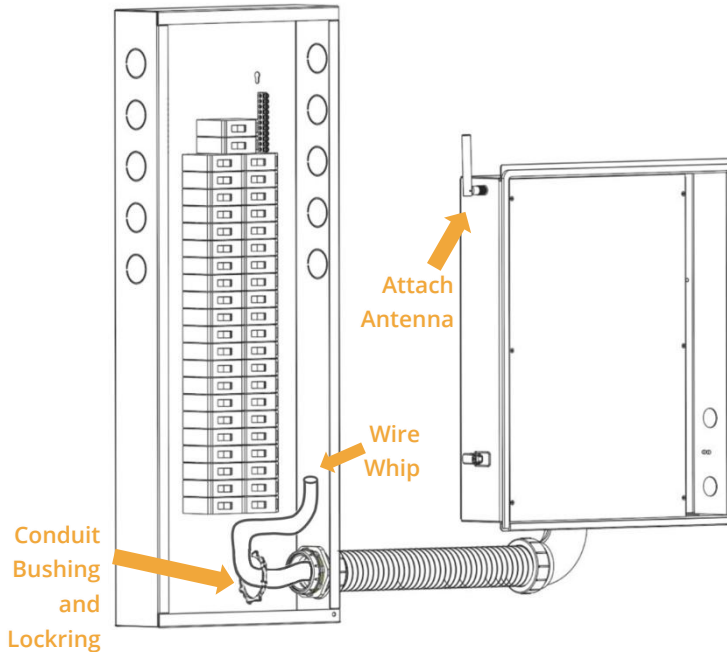

WARNING: HIGH VOLTAGE. ENSURE MAIN BREAKER IS OFF. MAIN SERVICE LINES ARE ALWAYS LIVE.
AVERTISSEMENT: HAUTE TENSION. ASSUREZ-VOUS QUE LE DISJONCTEUR PRINCIPAL EST ÉTEINT. LES CONDUCTEURS DE SERVICE PRINCIPAUX SONT TOUJOURS SOUS TENSION.

NOTE: Attach the antenna provided with the LSP and then guide the wire whip through the knockout in the electrical panel. Remove the conduit bushing and locking before guiding the wire whip through the hole.

STEP 7. Secure LSP to Wall/Bracket and Electrical Panel

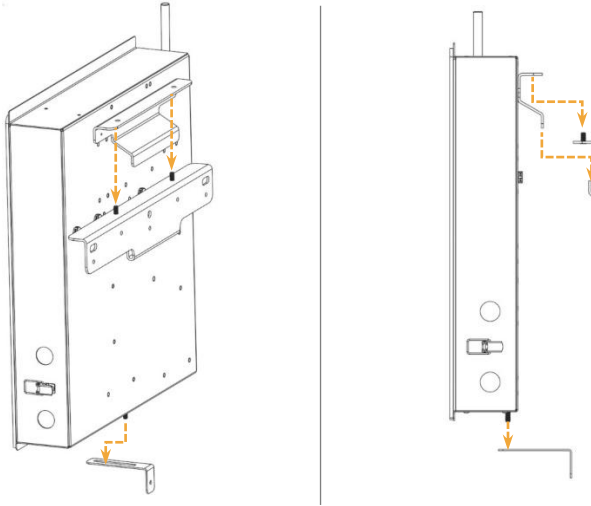

WARNING: HIGH VOLTAGE. ENSURE MAIN BREAKER IS OFF. MAIN SERVICE LINES ARE ALWAYS LIVE.
AVERTISSEMENT: HAUTE TENSION. ASSUREZ-VOUS QUE LE DISJONCTEUR PRINCIPAL EST ÉTEINT. LES CONDUCTEURS DE SERVICE PRINCIPAUX SONT TOUJOURS SOUS TENSION.

Tools: Drill, washer, and nuts (x3)

NOTE: Lift the LSP to align with the mounting holes and secure it to the mounting brackets utilizing the hardware provided. Use two nuts with the upper bracket. Use a washer and nut to position the LSP in the lower bracket slot such that the LSP is vertical (front face plumb). Secure the LSP conduit to the electrical panel with the locking and 2" conduit bushing provided.

STEP 8. Connect LSP Equipment Grounding Conductor (EGC) to Ground Bar

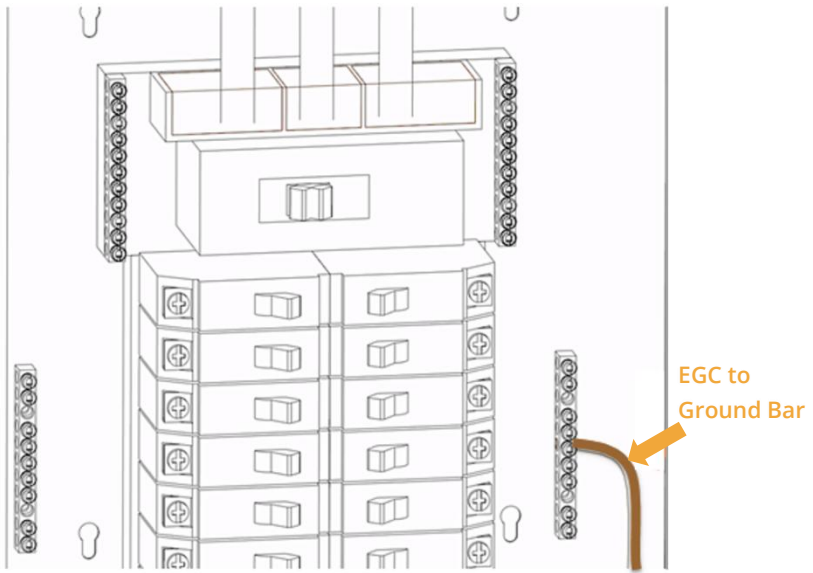

WARNING: HIGH VOLTAGE. ENSURE MAIN BREAKER IS OFF. MAIN SERVICE LINES ARE ALWAYS LIVE. GROUND WIRE MUST BE INSTALLED FOR SAFETY.
AVERTISSEMENT: HAUTE TENSION. ASSUREZ-VOUS QUE LE DISJONCTEUR PRINCIPAL EST ÉTEINT. LES CONDUCTEURS DE SERVICE PRINCIPAUX SONT TOUJOURS SOUS TENSION. UN FIL DE TERRE DOIT ÊTRE INSTALLÉ POUR LA SÉCURITÉ.

Tools: Screwdriver and pliers (optional)

NOTE: Connect the EGC (bare copper wire) from the LSP to the existing ground bar in the electrical panel (exact location of ground bar may vary).

STEP 9. Identify A-Row and B-Row Breakers

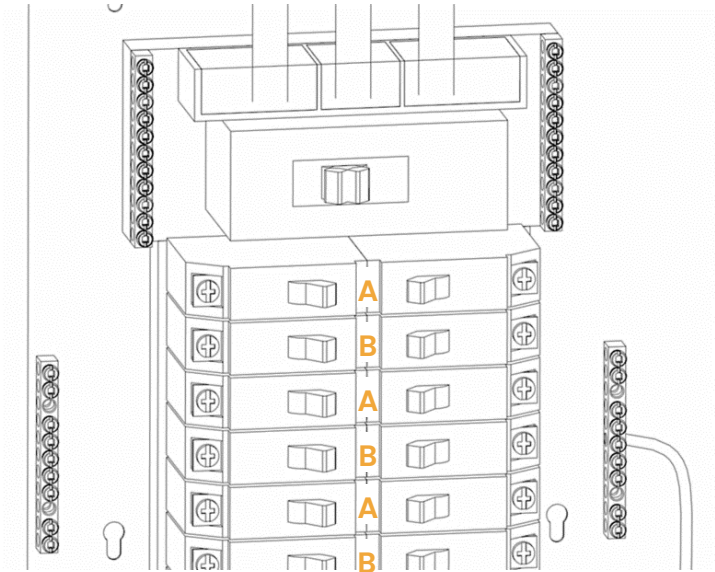

NOTE: For purposes of Lumin installation, the top row of breakers will **always** be classified as “A”. The second row of standard breakers will be “B”. The alternating A-B-A-B pattern continues down the rows of breakers. **Exception:** All breaker rows are designated “A” in panels with two-wire single-phase power rather than three-wire single-phase (split phase).

NOTE: If the electrical panel contains tandem or “skinny” breakers, there will be two breakers in a standard breaker space. Thus, the top-to-bottom breaker panel will be A-A-B-B-A-A-B-B.

STEP 10. Connect LSP Power Circuit and Label Breaker

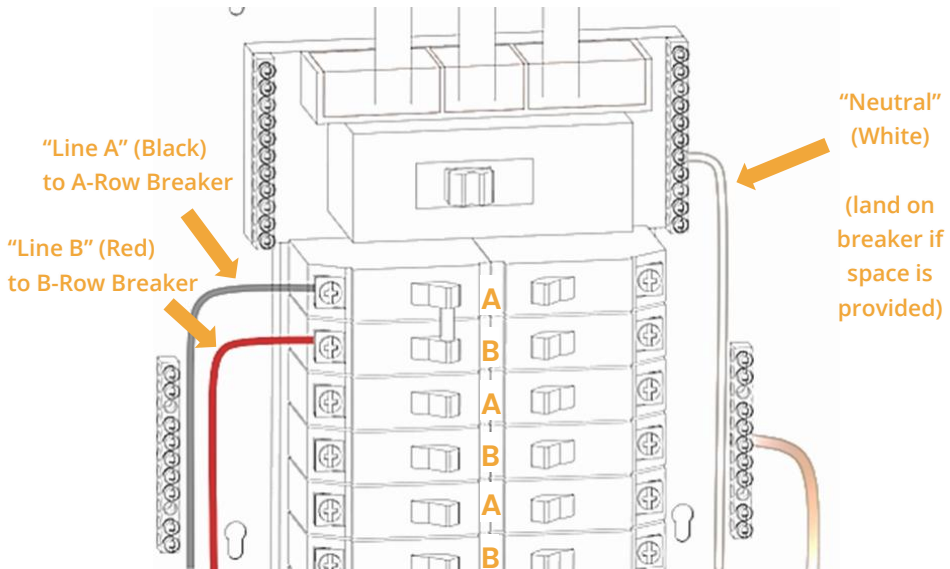

WARNING: HIGH VOLTAGE. ENSURE MAIN BREAKER IS OFF. MAIN SERVICE LINES ARE ALWAYS LIVE.
AVERTISSEMENT: HAUTE TENSION. ASSUREZ-VOUS QUE LE DISJONCTEUR PRINCIPAL EST ÉTEINT. LES CONDUCTEURS DE SERVICE PRINCIPAUX SONT TOUJOURS SOUS TENSION.

Tools: Screwdriver, pliers, and wire stripper

NOTE: Connect the LSP wires as pictured to the existing neutral bar and a double-pole 15- to 20-amp breaker, landing Line A (black wire) on an A Leg (odd-row breaker) terminal and Line B (red wire) on a B Leg (even-row breaker) terminal. Mark the breaker with a clearly identifying label (e.g., "Lumin Smart Panel Power"). **If using a GFCI breaker, ensure that the Lumin neutral is connected to the breaker and the breaker neutral is terminated on the neutral bar.** Do not double-tap breakers unless they are appropriately rated.

STEP 11. Select Circuit Breaker to Connect to LSP and Disconnect Load Wire

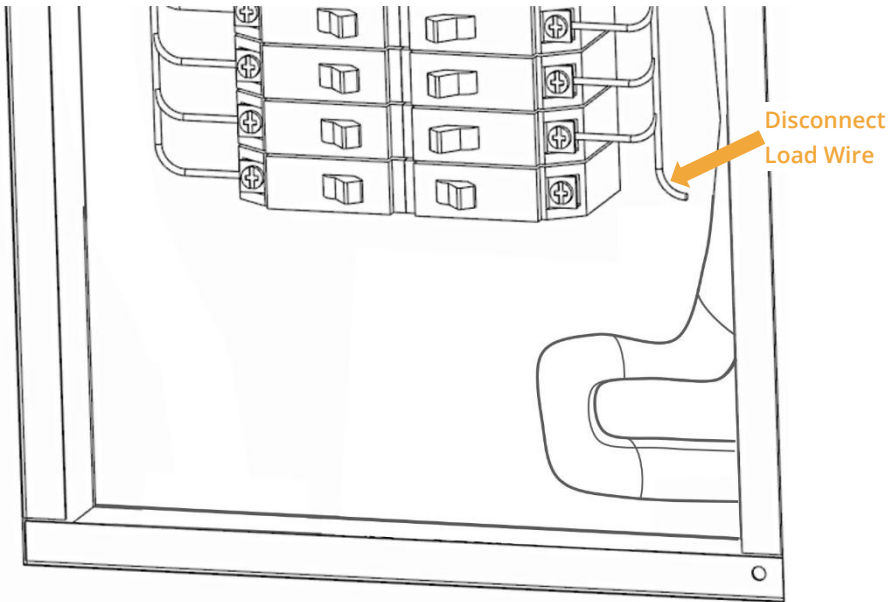

⚠ WARNING: HIGH VOLTAGE. ENSURE MAIN BREAKER IS OFF. MAIN SERVICE LINES ARE ALWAYS LIVE.
AVERTISSEMENT: HAUTE TENSION. ASSUREZ-VOUS QUE LE DISJONCTEUR PRINCIPAL EST ÉTEINT. LES CONDUCTEURS DE SERVICE PRINCIPAUX SONT TOUJOURS SOUS TENSION.

Tools: Screwdriver

NOTE: Breaker labels should be marked using the provided stickers to indicate that the load is controlled by the LSP. **In typical applications, do not connect breakers that power the router(s)/modem(s) that provide the LSP Internet connection.**

STEP 12. Connect LSP Wire Labeled “Line 1 Breaker” to Circuit Breaker

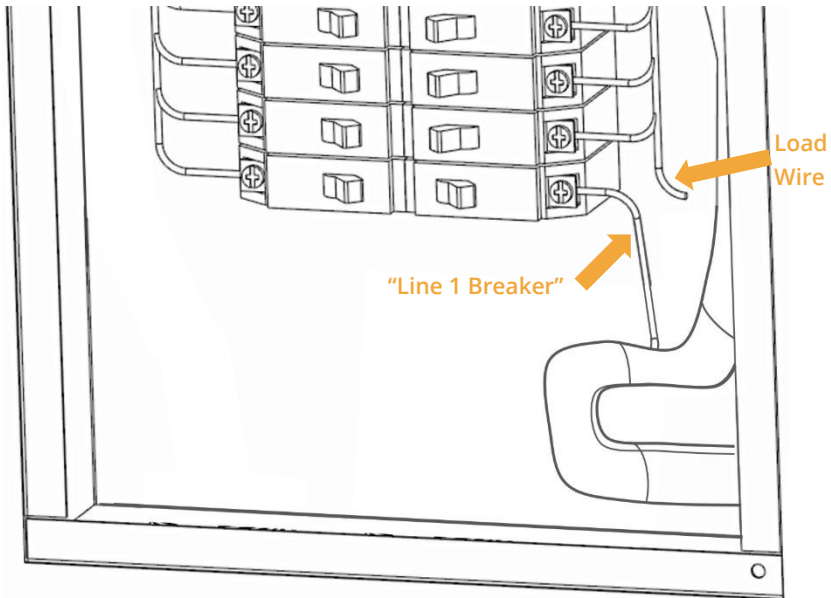

WARNING: HIGH VOLTAGE. ENSURE MAIN BREAKER IS OFF. MAIN SERVICE LINES ARE ALWAYS LIVE.
AVERTISSEMENT: HAUTE TENSION. ASSUREZ-VOUS QUE LE DISJONCTEUR PRINCIPAL EST ÉTEINT. LES CONDUCTEURS DE SERVICE PRINCIPAUX SONT TOUJOURS SOUS TENSION.

Tools: Screwdriver and wire stripper

NOTE: All LSP wires labeled “Line # Breaker” must connect to a breaker or be safely terminated with a wire connector/cap. Lines 1-6 (6 AWG wire) can connect to circuit breakers rated up to 60 amps and lines 7-12 (10 AWG wire) can connect to circuit breakers rated up to 30 amps (see pg. 38).

STEP 13. Connect LSP Wire Labeled “Line 1 Load” to Load

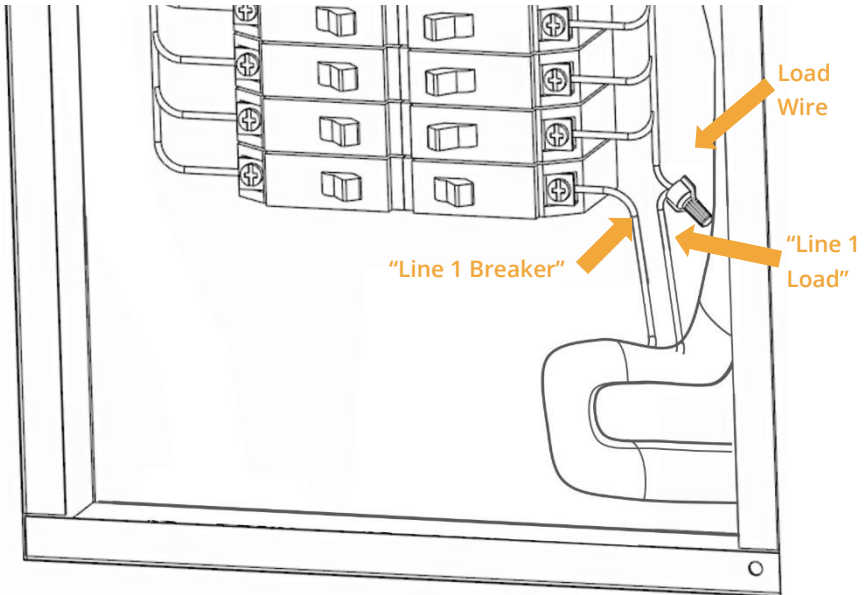

WARNING: HIGH VOLTAGE. ENSURE MAIN BREAKER IS OFF. MAIN SERVICE LINES ARE ALWAYS LIVE.
AVERTISSEMENT: HAUTE TENSION. ASSUREZ-VOUS QUE LE DISJONCTEUR PRINCIPAL EST ÉTEINT. LES CONDUCTEURS DE SERVICE PRINCIPAUX SONT TOUJOURS SOUS TENSION.

Tools: Wire stripper and wire splice connector

NOTE: All LSP wires labeled “Line # Load” must connect to a load wire via a wire splice connector (ensuring a tight connection) or be safely terminated with a wire connector. The LSP wire line number must match the line number used in the previous step (e.g., “Line 3 Breaker” connects to a breaker and “Line 3 Load” connects to that breaker’s load).

STEP 14. Record Circuit Name and Breaker Row (A/B) With Corresponding LSP Line Number

LSP LINE #	BREAKER ROW (circle one)	CIRCUIT BREAKER LABEL/NAME	LSP LINE #	BREAKER ROW (circle one)	CIRCUIT BREAKER LABEL/NAME
1	A	<i>Pool Pump</i> Single-pole circuit	7	A	
	<input checked="" type="radio"/> B				
2	A	<i>Range</i> Double-pole circuit	8	A	
	B				
3	A	<i>Range</i>	9	A	
	<input checked="" type="radio"/> B				
4	A		10	A	
	B				
5	A		11	A	
	B				
6	A		12	A	
	B				
CURRENT TRANSFORMER (CT)			CURRENT TRANSFORMER (CT)		
Line A/B CTs			Aux. A/B CTs (Optional)		

NOTE: Record the circuit label/name and breaker row (A or B) with the corresponding LSP line number in the *LSP Circuit Label & CT Table* provided with the LSP (e.g., LSP Line 1 is landed on a B-row breaker that protects the pool pump. Record “Pool Pump” next to LSP Line 1 and circle Breaker Row “B”). Double-pole circuit breakers will require two LSP wire sets, and thus two LSP line numbers.

STEP 15. Repeat Steps 11-14 Until All LSP Line # Wires Are Connected

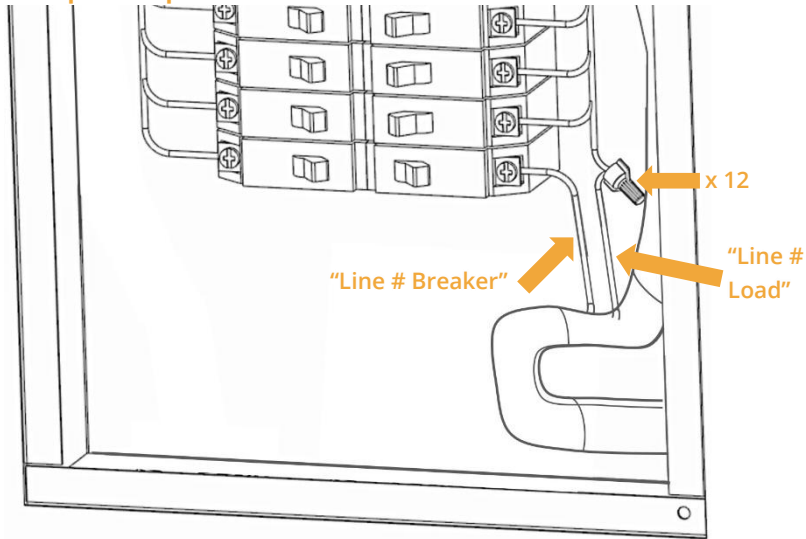

 **WARNING: HIGH VOLTAGE.**
AVERTISSEMENT: HAUTE TENSION.

Tools: Screwdriver, wire stripper, and wire splice connectors

NOTE: All LSP wires labeled "Breaker" must connect to a breaker. Lines 1-6 (6 AWG wire) can connect to circuit breakers rated up to 60 A and lines 7-12 (10 AWG wire) can connect to circuit breakers rated up to 30 A (see pg. 38).

NOTE: The LSP can connect to up to 12 single-pole (or six double-pole) circuit breakers. Each hot leg of a double-pole circuit must be connected to its own numbered Lumin wire set (e.g., LSP controls a clothes dryer. Dryer Leg "A" is connected to LSP Line 3. Dryer Leg "B" is connected to LSP Line 4).

NOTE: Controlling the circuit that powers the Internet/LAN equipment is not recommended; app access to the LSP will be lost when this circuit is switched off.

STEP 16. Determine Placement of Current Transformers (CTs)

DO NOT INSTALL CTS UNTIL PROPER LOCATION AND PHASING HAVE BEEN DETERMINED.

Each LSP is supplied with one set of two (2) 200-amp current transformers (CTs). The LSP is equipped with leads for these main CTs (labeled “Line A CT” and “Line B CT”) as well as leads for an optional set of auxiliary CTs, available for purchase from Lumin and only used when solar is backed into the electrical panel as shown below. When auxiliary CTs are not used the unused “aux” leads should be coiled neatly in the electrical panel. For any situation other than the two shown below, contact Lumin support for CT placement advice.

Note (Panel Guard Only): Main CTs are not required if using Lumin in a “branch limiting” configuration, where only a portion of the home’s circuits need to be monitored and controlled. See Lumin Certified Installer training for more details about this configuration.



luminsmart.learnworlds.com

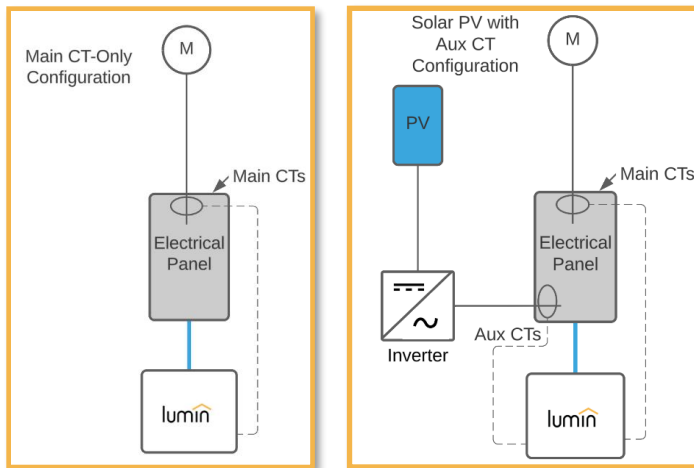

Figure A – CT Configurations

STEP 17. Phase Conductors Monitored by Current Transformers

REMINDER: In a Lumin installation, the top* row of breakers in an electrical panel is *always* designated “A.” Whichever conductor supplies breaker Row A will be designated “Line A.”

NOTE: Lumin CTs are designated either “Line A” or “Line B”. Placing them on the incorrect leg of a circuit will result in erroneous consumption data.



Figure A – Typical Main-Lug-Only Electrical Panel Busing

If the panel is a main-lug-only type, as shown in Figure B (no main circuit breaker), then the feeder on the left will be Lumin Leg “A”.

If the panel includes a main circuit breaker, note that the main breaker may contain crossover busing, with the result that the feeder on the left feeds the right-side bus bar and the feeder on the right feeds the left-side bus bar. To identify A/B feeders when a main breaker is present, consult the following page.

* All descriptions assume a top-fed electrical panel.

STEP 18. Test for Breaker Crossover before Current Transformer Placement

REMINDER: In a Lumin installation, the top* row of breakers in an electrical panel is *always* designated "A." Whichever conductor supplies breaker Row A will be designated "Line A."

To determine which service conductor or feeder is Line A and which is Line B when a main circuit breaker is present, switch the main breaker to the closed/on position. Test for AC voltage between the left lug and the left bus bar*. If the bus bar is not accessible, test between the left lug and the terminal on the top left circuit breaker. See Figure C.

If VAC between these points is ≈ 240 , the main breaker contains crossover busing. Place CT A on the right and CT B on the left. If VAC between these points ≈ 0 , the main breaker is a standard type (no internal busing).

Switch the main breaker to the open/off position once the voltage readings are complete.

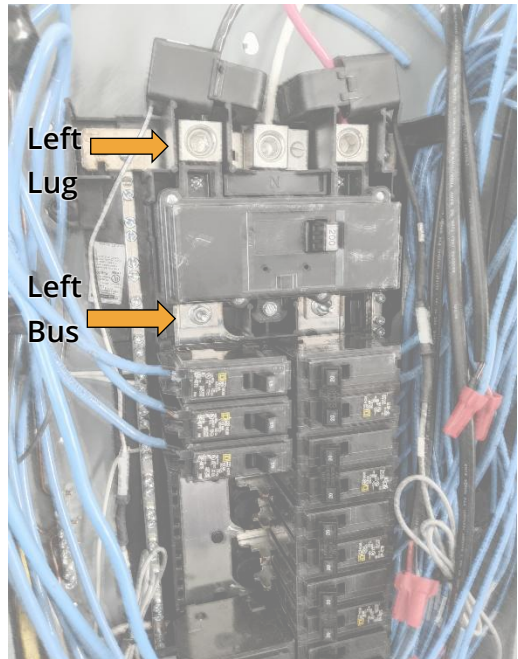

Figure B - Typical Main Breaker Electrical Panel

Tools: Multimeter

* All descriptions assume a top-fed electrical panel.



WARNING: HIGH VOLTAGE.
AVERTISSEMENT: HAUTE TENSION.

STEP 19. Connect Current Transformers

Prior to installation, measure the CT leads' routing path(s) in the electrical panel. Local electrical codes may require securing CT wiring at regular intervals. If the provided leads are not long enough, fashion CT wire extensions in the field. Scan the adjacent code for information on the proper extension procedures.



Connect CTs to their corresponding CT leads coming from the Lumin conduit **before** clamping the CTs around the conductors to be measured. The CT marked with "A" should attach to Leg A and the CT marked with "B" should attach to Leg B. Ensure the sticker on the CT reading "This side toward grid" is facing toward the grid/utility meter.

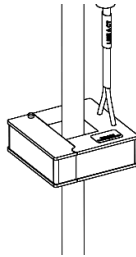

WARNING: HIGH VOLTAGE. MAIN SERVICE LINES ARE ALWAYS LIVE.
AVERTISSEMENT: HAUTE TENSION. LES CONDUCTEURS DE SERVICE PRINCIPAUX SONT TOUJOURS SOUS TENSION.

CAUTION: A CT SHOULD NEVER BE LEFT CLAMPED ON A CONDUCTOR WHEN THE CT WIRING IS DISCONNECTED. SATURATION AND DESTRUCTION OF THE CT CORE MAY RESULT. CONNECT CT WIRING BEFORE CLAMPING. UNCLAMP BEFORE DISCONNECTING CT WIRING.

ATTENTION: UN TRANSFORMATEUR DE COURANT NE DOIT JAMAIS ÊTRE LAISSÉ SERRÉ SUR UN CONDUCTEUR LORSQUE LES FILS DU TRANSFORMATEUR DE COURANT SONT DÉCONNECTÉS. LA SATURATION ET LA DESTRUCTION DU NOYAU PEUVENT EN RÉSULTER. CONNECTER LES CÂBLES DU TRANSFORMATEUR DE COURANT AU LSP AVANT L'INSTALLATION. DÉSINSTALLEZ LE TRANSFORMATEUR DE COURANT AVANT DE DÉBRANCHER SON CÂBLE.

STEP 20. Record the Placement of Current Transformers

LSP LINE #	BREAKER ROW (circle one)	CIRCUIT BREAKER LABEL/NAME	LSP LINE #	BREAKER ROW (circle one)	CIRCUIT BREAKER LABEL/NAME
1	A		7	A	
	B			B	
2	A		8	A	
	B			B	
3	A		9	A	
	B			B	
4	A		10	A	
	B			B	
5	A		11	A	
	B			B	
6	A		12	A	
	B			B	
		CURRENT TRANSFORMER (CT)			CURRENT TRANSFORMER (CT)
Line A/B CTs		<i>Ex. Main Service Lines</i>	Aux. A/B CTs (Optional)		<i>Ex. Solar Output</i>

In the *LSP Circuit Label & CT Table*, record the location of the CTs. For example, record “Main Service Lines” next to “Line A/B CTs” if the CTs are clamped around the service lines. If auxiliary CTs are not used, leave the “Aux A/B CT” space blank.

STEP 21. Connect Grid Detect Circuit (GDC) (Required for Off-Grid Manager)

For installations that will include **Off-Grid Manager**: Connect the Grid Detection Circuit (GDC) to the grid side of a Microgrid Interconnect Device (MID). The GDC monitors the presence of grid voltage. The GDC must be wired so that it is not backed up by storage or a generator. Land the wire labeled “Grid Neutral” at the most upstream neutral bar or terminal possible. Extend the “Grid Line” wire to a portion of the premises wiring that will lose voltage during a grid outage. Extend using a suitable wire splice connector and wiring #12 AWG or larger and land it on a non-backed-up circuit breaker or perform a supply-side connection (aka “line-side tap”). There is a 1 A fuse on this circuit inside the smart panel enclosure, however additional overcurrent protection may be required depending on local code and the location and length of the circuit.

Tools: Wire splice connectors.

NOTE: For installations that will only utilize Panel Guard and not Off-Grid Manager, the Grid Detection Circuit is not used. Use wire nuts to cap off wires labeled “Grid Line” and “Grid Neutral” and coil these conductors in the bottom of the panel.

STEP 22. Replace Electrical Panel Cover and Remove LSP Cover

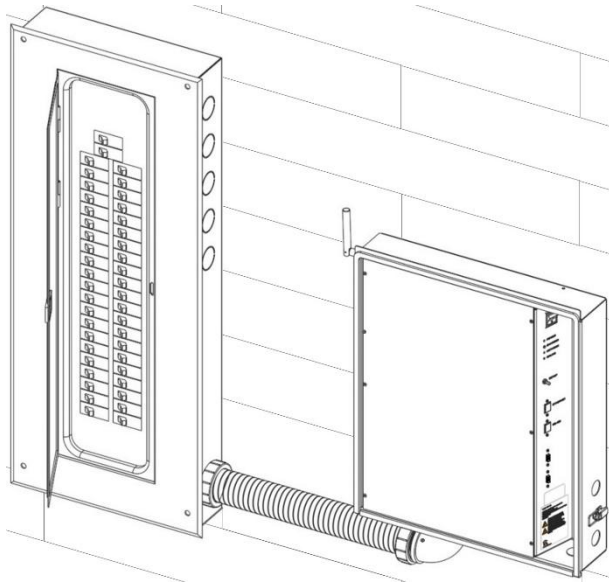

WARNING: HIGH VOLTAGE. ENSURE MAIN BREAKER IS OFF. MAIN SERVICE LINES ARE ALWAYS LIVE.
AVERTISSEMENT: HAUTE TENSION. ASSUREZ-VOUS QUE LE DISJONCTEUR PRINCIPAL EST ÉTEINT. LES CONDUCTEURS DE SERVICE PRINCIPAUX SONT TOUJOURS SOUS TENSION.

Tools: Screwdriver

NOTE: Please make any necessary exterior wall repairs (if applicable) and clean up the area around the electrical panel once the LSP installation is completed. If the LSP cover has not been removed, remove it: unlatch the toggle clamps from both sides, unscrew the two screws at the bottom of the cover and pull the bottom of the cover away while lifting upwards.

STEP 23. Energize the Electrical Panel and Turn On the LSP

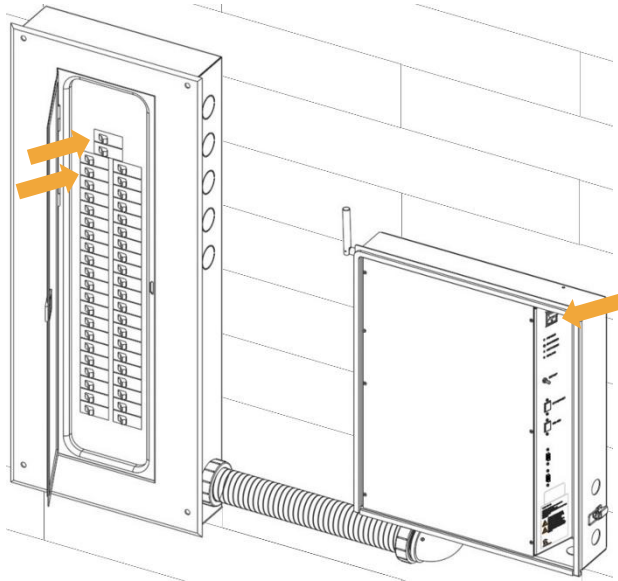

Tools: Screwdriver

NOTE: Ensure the LSP power switch is set to ON (I). Then, turn on the main breaker and the Lumin Power Circuit breaker (the breaker from **Step 10**).

STEP 24. LSP Configuration

Configuration and Account Setup

Please note that the configuration and account setup process may change as the Lumin Energy app is updated. The steps below are a generalized version of the commissioning process. To view more detailed information on this process, refer to our Knowledge Base by going to luminenergy.freshdesk.com or scanning the code.



1. After completing the hardware installation, ensure the LSP power switch is in the "ON" position ("I"). The blue and green indicator lights will begin blinking in unison, indicating that the LSP is ready for commissioning.
2. If feasible, make an Ethernet connection between the Lumin Smart Panel's Ethernet port and a LAN port on the location's router. This Ethernet connection is more reliable than a WiFi connection and is not affected by replacing the router or resetting the WiFi password. Use the 3/4" trade size knockouts in the LSP and liquidtight conduit to route Ethernet cable.
3. Download the Lumin Energy mobile app (<https://get.lumin.energy>). In the Apple App Store or Google Play Store, search for "Lumin Energy".
4. Log in with an existing account or create a new account. **You must complete Certified Installer training before setting up a system in the app.**
5. Select "Get Started" and follow the in-app instructions to set up your Lumin Smart Panel **(completed LSP Circuit Label & CT Table required).**

Need help? For account setup assistance or troubleshooting, please call 1-888-421-0616 (North America) or e-mail support@luminsmart.com.

STEP 25. Complete Current Limiting Label (for installations with Panel Guard)

NOTE: Record the maximum current setting entered into the Lumin Energy app (maximum 80% of main breaker rating).

The maximum current setting is normally not changed after initial installation. It can only be changed by a user of the system who has completed Lumin Certified Installer training. Changes to this setting can only be done locally, while connected to the same network as the Lumin Smart Panel.

Complete the rest of the current limiting label, including the list of controlled loads/circuits connected to the Lumin Smart Panel.

Need help? For account setup assistance or troubleshooting, please call 1-888-421-0616 (North America) or e-mail support@luminsmart.com.

The setting for the EMS current limiting feature **shall not be bypassed**

COMPANY NAME:

LUMIN CERTIFIED INSTALLER:

MAXIMUM CURRENT SETTING:

DATE OF CALCULATION AND SETTING:

IDENTIFY CONTROLLED LOADS:

1

2

3

4

5

6

7

8

9

10

11

12

lumin



STEP 26. Apply Labels

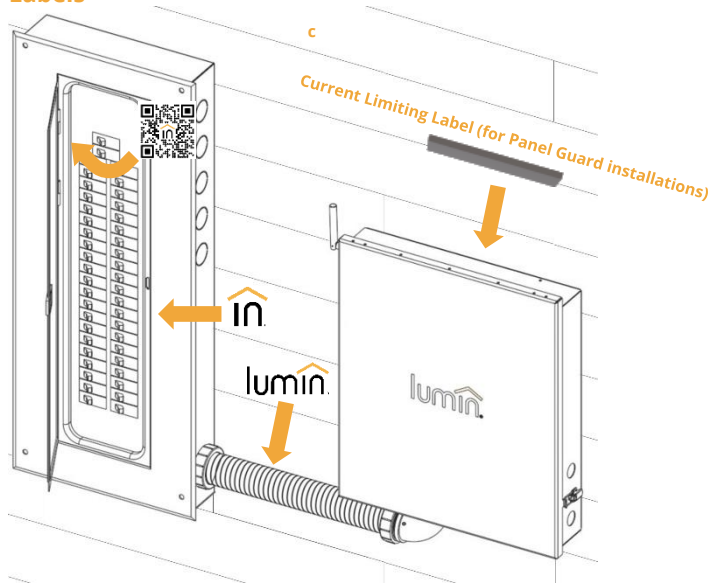

WARNING: ELECTRICAL CODES MAY REQUIRE ADDITIONAL LABELING.

AVERTISSEMENT: LES CODES ELECTRIQUES PEUVENT NECESSITER UN ETIQUETAGE SUPPLEMENTAIRE.

Tools: Screwdriver

NOTE: The National Electrical Code requires additional labeling for energy management systems such as the LSP. The provided installation materials include labels to identify the LSP-managed circuits in the electrical panel, LSP electrical conduit/raceway, and informational QR code labels. Apply label stickers as shown above and as detailed on the provided sticker sheets. Electrical code requirements may vary depending on the installation location.

STEP 27. Reinstall and Secure LSP Cover

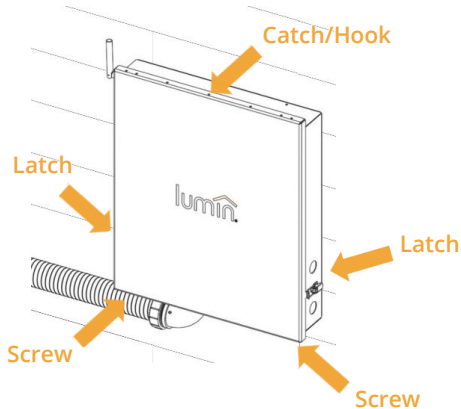

WARNING: FOR ALL OUTDOOR INSTALLATIONS, OPERATING THE LSP WITH THE COVER REMOVED DURING INCLEMENT WEATHER (RAIN, SNOW, SLEET, DUSTY CONDITIONS, ETC) WILL VOID THE WARRANTY. THE NEMA RATING IS ONLY APPLICABLE WITH THE COVER INSTALLED. NORMAL OPERATION/INSTALLATION OF THE LSP INCLUDES THE INSTALLATION OF THE COVER.

AVERTISSEMENT: POUR TOUTES LES INSTALLATIONS À L'EXTÉRIEUR, LE FONCTIONNEMENT DU LSP AVEC LE COUVERCLE RETIRÉ LORS DE TEMPS MAUVAIS (PLUIE, NEIGE, GLACÉ, CONDITIONS POUSSIÉREUSES, ETC.) ANNULERA LA GARANTIE. LA CERTIFICATION NEMA N'EST APPLICABLE QU'AVEC LE COUVERCLE INSTALLÉ. LE FONCTIONNEMENT/L'INSTALLATION NORMAUX DU LSP COMPREND L'INSTALLATION DU COUVERCLE.

Tools: Screwdriver

NOTE: Once the Configuration and Account Setup procedures are complete, reinstall the LSP cover by hooking the catch pins over the top flange, securing the latches, and installing the two screws that interfere with removal of the cover. Per the National Electric Code, the cover must remain in place during operation to prevent the end user from accessing the power switch.

TROUBLESHOOTING AND REPAIRS

End User

If the LSP is not functioning as expected, ensure that Internet service is available, antenna/Ethernet connection is secure, and breakers are switched on. See Operational Information (pg. 37) on how to read the LSP indicators for Internet connectivity status. It is best to obtain assistance from a qualified installer for further troubleshooting of hardware issues. The installer's familiarity with Lumin products and ability to perform electrical work will help resolve issues effectively. Alternatively, contact Lumin directly for assistance.

Qualified Installer

Observe all safety precautions listed on Page 3. Never use the LSP to de-energize circuits to perform electrical work. The LSP is not designed for safety disconnecting means; lock-out/tag-out is not possible. If not properly connected the app may falsely indicate that a circuit is de-energized, so always assume that LSP circuits are live.

Lumin Certified Installer training is required before Lumin will authorize work on an existing LSP. Case-specific authorization and instruction will be provided by Lumin if applicable. Do not open cover or attempt repairs otherwise — even with breakers off hazardous voltages may be present. **Neither the LSP power circuit breaker nor the LSP power switch de-energize the internal product components.** The main breaker and all other power sources must be de-energized to ensure the LSP is safe to work on. *Fuses: LSP Power – non-replaceable 2.5 A; GDC – 1 A, slow blow.*



DANGER: HAZARDOUS VOLTAGES PRESENT DURING INSTALLATION AND SERVICING. DO NOT OPEN LSP COVER, INSPECT INSTALLATION WIRING, OR ATTEMPT REPAIRS WITHOUT REQUIRED QUALIFICATIONS AND LUMIN AUTHORIZATION. ALWAYS DISCONNECT ELECTRICAL SUPPLY BEFORE PERFORMING REPAIRS.



DANGER: TENSIONS DANGEREUSES PRÉSENTES LORS L'INSTALLATION ET L'ENTRETIEN. NE PAS OUVRIR LE COUVERCLE DU LSP, INSPECTER LE CÂBLAGE D'INSTALLATION OU ESSAYER DE RÉPARER SANS QUALIFICATIONS REQUISES ET AUTORISATION DE LUMIN. TOUJOURS DÉBRANCHER L'ALIMENTATION ÉLECTRIQUE AVANT D'EFFECTUER DES RÉPARATIONS.

OPERATIONAL INFORMATION

LED Indicator	Off	On
Red “Power”	Power Off or Not Present	Power On
Red “Charged”	Temporary Power Unit Charging	Temporary Power Unit Charged

LED Indicator	Off	Both Blinking	Just One Blinking	Both Solid
Green “Network”	Lumin Server Disconnected	Setup Mode. WiFi connectivity is disabled. Press and release “Setup” button to exit	(When blue is solid) Lumin server error	Fully connected via WiFi
Blue “Online”	No Internet Connection via WiFi		Attempting to connect to the Internet	

NOTE: Simultaneous blue and green blinking lights indicate that the LSP is in Setup Mode. This is the required mode for initial setup and commissioning. However, the LSP does not connect to the Internet via WiFi in this mode. If both lights are seen blinking during normal operation, it is likely that the “Setup” button was pressed, taking the LSP offline. In most instances, an additional press-and-release of the “Setup” button will bring the LSP back online. It may take about 45 seconds to restore the connection and display two solid unblinking indicator lights.

NOTE: During an Internet outage, local connection can be made between an LSP and the user's mobile device as long as the device and the LSP are connected to the same network. Ensure that the LSP is not in Setup Mode and that WiFi connectivity is enabled on the mobile device.

Need help? For additional support documentation, visit luminpanelguard.freshdesk.com or scan the code at right:





PRODUCT SPECIFICATIONS

INSTALLATION	
Type	Surface-Mount; Indoor or Outdoor
Installer Qualification	Local Electrical Codes and Lumin Certified Installer
Typical Time Required	1.5–4 Hours
NEMA Rating	Type 3R
Temperature	-30°C to 70°C (-22°F to 158°F)
Humidity	< 100% RH
Altitude	< 3000 m
Pollution Level	Degree 3
Dimensions	55.8 cm × 48.3 cm × 14.0 cm (22 in × 19 in × 5.5 in)
Weight	12 kg (27 lb)
Conductor Length	All Extend min 100 cm (40 in) Beyond Conduit End
Additional Units	One (1) Lumin Smart Panel per electrical panel for service upsize avoidance
CONNECTIVITY & SECURITY	
Connection Options	WiFi or Ethernet
Internet Bandwidth	Approx. 0.02 Mbps
WiFi Protocols	802.11 b/g/n, 2.4 GHz
WiFi Encryption	WPA and WPA2 Methods
Ethernet Port	1×RJ-45 (10/100/1000 Mbps)
IP Addressing	Dynamic (DHCP)
Cryptographic System	TLS 1.2 (Minimum)
Firewall Outbound Access Required	Ports 53, 123, 443–444, and 50050–50059
USER ACCESS	
Local Network	Live Data and Controls
Applications	iOS, Android, and Web
Data	1-Second Granularity (Averaged from 16 kHz)
Load Controls	Manually/Directly, Automated Schedules, and Automated Modes

ELECTRICAL SYSTEM	
AC Voltage	120/240 VAC Split-Phase, 50–60Hz
Supply Breaker Rating	15–20 A (non-GFCI)
Supply Amperage	0.4 A (Maximum)
Standby Power	6 W
Voltage Fluctuations	±10% from Nominal
Overvoltage	Category III (Building Wiring)
TPU	Load Shedding; Supports Toggling All Lines a Minimum of Once During a Power Outage
MANAGED LOADS	
Max. Load Breaker Ratings up to 50 °C	60 A per Line × 6 Lines and 30 A per Line × 6 Lines
Load Breaker Ratings at 50-60 °C	50 A per Line × 6 Lines and 20 A per Line × 6 Lines
Load Breaker Ratings at 60-70 °C	40 A per Line × 6 Lines and 15 A per Line × 6 Lines
Breaker Types	Single Pole (1 Line) and Dual Pole (2 Lines)
MEASUREMENT	
Accuracy	±0.5% of Load
Monitoring Type	Separate Measurement of Lines (Including Dual-Pole)
Split-Phase Voltage	Separate Line-to-Neutral Potential Measurement
Current Transformers	2 Split-Core 200 A Included; Up to 2 Additional Available
Measurement Category	Loads: CAT III (Mains Distr.) GDC: CAT IV (Mains Source)
SUPPORT & COMPLIANCE	
Warranty	10-Year Limited
Compatible Equipment	All Makes/Models/Brands of Electrical Panels and Breakers
Safety Compliance	MET Listing E115439; UL 916, CSA C22.2 No.205, and UL/CSA 61010
Radiofrequency Compliance	47 CFR 15 (FCC) RSS-Gen and RSP-100 (ISED)

LIMITED WARRANTY FOR LUMIN SMART PANEL

This Limited Warranty gives you specific legal rights and you may also have other rights, which vary from state to state. We warrant that during the warranty period, the product will be free from defects in materials and workmanship. To the maximum extent allowable under applicable law, this Limited Warranty is offered in lieu of, and we fully disclaim, any and all implied warranties and any implied remedies, including without limitation the warranties of merchantability and fitness for a particular purpose. Some states do not allow disclaimers of certain implied warranties or limitations on how long certain implied warranties last, so the above limitations may not apply to you. To the maximum extent allowable under applicable law, our responsibility for defective goods is limited to repair, replacement, or refund as described below in this warranty statement.

Who May Use This Warranty? Coulomb Inc. (d/b/a Lumin), a Delaware corporation located at address 501 Locust Ave, Floor 1, Suite 2, Charlottesville, VA 22902 (“we”) extends this limited warranty only to the consumer who originally activated the product and connected it to a Lumin Account (through luminsmart.com) and to any subsequent owner or other transferee of the product (“you”).

What Does This Warranty Cover? This limited warranty covers defects in materials and workmanship of the Lumin Smart Panel (the “product”) for the Warranty Period as defined below.

What Does This Warranty Not Cover? This limited warranty does not cover any damage due to: (a) transportation; (b) storage; (c) improper installation; (d) improper use; (e) failure to follow the product instructions; (f) failure to adhere to the product’s technical specifications, including product’s environmental and electrical ratings; (g) modifications; (h) unauthorized opening of the product’s cover; (i) tampering with the product’s internal components; (j) unauthorized repair; (k) normal wear and tear; (l) external causes such as accidents, abuse, flooding, lightning strikes, storms or other actions or events beyond our reasonable control; or (m) user error, including acts or omissions of any end user or any administrator (other than where Lumin acts as sole administrator). This limited warranty also does not apply to the software, mobile applications, technology and services provided by Lumin which enable you to remotely access and view data that is collected, stored and transmitted by the product concerning electricity consumption and/or to remotely control electrical circuits which the product is connected to (the “Lumin Service”). Use of the Lumin Service is subject to and governed by the terms of the Lumin Service User Agreement, a copy of which can be accessed at luminsmart.com/consent-documentation/. The warranties expressly set forth in the Lumin Service User Agreement are the sole and exclusive warranties that apply to the Lumin Services.

What Is the Period of Coverage? The “Warranty Period” for this limited warranty starts on the date the product is first activated and connected to a Lumin Account (through luminsmart.com) and lasts (a) for two years for the product’s sensor boards and the processor board, including individual components that make up the sensor boards and processor board, and (b) for ten years for all other components of the product. The Warranty Period is not extended if we repair or replace the product. We may change the availability of this limited warranty at our discretion, but any changes will not be retroactive.

What Are Your Remedies Under This Warranty? With respect to any product that we have verified is defective in materials or workmanship based on a claim made during the applicable Warranty Period, we will, in our sole discretion, either: (a) repair or replace such product (or the defective part) free of charge or (b) refund the purchase price of such product. We will also pay for shipping and handling fees to return the repaired or replacement product to you if we elect to repair or replace the defective product.

How Do You Obtain Warranty Service? To obtain warranty service, you must call 1-888-421-0616 or e-mail support@luminsmart.com during the Warranty Period to make a warranty claim. We will evaluate the claim and may require you to provide information and documentation to substantiate the claim, in our discretion. If we determine in our reasonable discretion that your claim is valid, we will provide you with a Defective Merchandise Authorization (“DMA”) number, which you can use to procure a repair, replacement, or refund, as described above, in our discretion. No warranty service will be provided without a DMA number.

Limitation of Liability. The remedies described above are your sole and exclusive remedies and our entire liability for any breach of this Limited Warranty. Notwithstanding anything to the contrary, our liability shall under no circumstances exceed the actual amount paid by you for the defective product, nor shall we under any circumstances be liable for any consequential, incidental, special or punitive damages or losses, whether direct or indirect. Some states do not allow the exclusion or limitation of incidental or consequential damages, so the above limitation or exclusion may not apply to you.



RADIO FREQUENCY STATEMENT

This device complies with Part 15 of the FCC rules and with Innovation, Science and Economic Development Canada's licence-exempt RSS(s). Operation is subject to the following two conditions:

1. This device may not cause interference.
2. This device must accept any interference, including interference that may cause undesired operation of the device.

L'émetteur/récepteur exempt de licence contenu dans le présent appareil est conforme à la partie 15 des règles de la FCC et aux CNR d'Innovation, Sciences et Développement économique Canada applicables aux appareils radio exempts de licence. L'exploitation est autorisée aux deux conditions suivantes:

1. L'appareil ne doit pas produire de brouillage;
2. L'appareil doit accepter tout brouillage radioélectrique subi, même si le brouillage est susceptible d'en compromettre le fonctionnement.

Changes or modifications not expressly approved by the party responsible for compliance could void the user's authority to operate the equipment.

The antennas used for this transmitter must be installed to provide a separation distance of at least 20cm from all persons and must not be located or operating in conjunction with any other antenna or transmitter.

Les antennes utilisées pour ce transmetteur doivent être installé en considérant une distance de séparation de toute personnes d'au moins 20 cm et ne doivent pas être localisé ou utilisé en conflit avec tout autre antenne ou transmetteur.

This radio transmitter 27016-LSP12WE (PMN: Lumin Smart Panel; HVIN: 8223A-SR) has been approved by Innovation, Science and Economic Development Canada to operate with the antenna types listed below, with the maximum permissible gain indicated. Antenna types not included in this list that have a gain greater than the maximum gain indicated for any type listed are strictly prohibited for use with this device.

1. Dipole type antenna, 2dBi maximum gain, 50 Ohm impedance

NOTE: This equipment has been tested and found to comply with the limits for a Class B digital device, pursuant to part 15 of the FCC Rules. These limits are designed to provide reasonable protection against harmful interference in a residential installation. This equipment generates, uses and can radiate radio frequency energy and, if not installed and used in accordance with the instructions, may cause harmful interference to radio communications. However, there is no guarantee that interference will not occur in a particular installation. If this equipment does cause harmful interference to radio or television reception, which can be determined by turning the equipment off and on, the user is encouraged to try to correct the interference by one or more of the following measures: (1) Reorient or relocate the receiving antenna. (2) Increase the separation between the equipment and receiver. (3) Connect the equipment into an outlet on a circuit different from that to which the receiver is connected. (4) Consult the dealer or an experienced radio/TV technician for help.



501 Locust Ave, Floor 1, Suite 2
Charlottesville, VA 22902

SUPPORT@LUMINSMART.COM
1-888-421-0616
WWW.LUMINSMART.COM

U.S. Patent No. 10,109,987
U.S. Patent No. 10,467,712
Canadian Patent No. 3,050,702

U.S. and International Patent Applications Pending.
® U.S. Registered Trademark.

Copyright © 2022 Coulomb, Inc. (DBA Lumin). All rights reserved.